

System Configurations & Cables

ICT Proprietary 3-wire Databus

The ICT proprietary Databus protocol operates on a three wire bus giving the customer maximum flexibility in the layout of their data logging system. The three wires of the Databus provide power and communication for all Smart sensors connected to the SL5 data logger. Due to the simplicity of this bus system, sensors and extension cables can be connected anywhere on the Databus. The Databus system uses the following wiring for all connected Smart sensors and extension cables:

Connector	Function	Sensor Cable Wire Colour	ICT Extension Cable Wire Colour
PIN 1	Power	Red	Red
PIN 2	Serial Data	Yellow	Yellow
PIN 3	Power and Data Ground	White	Blue & Green

System Configurations

Because the Databus cabling is all connected in parallel, Databus extension cables and sensor cables can be laid out in either radial or daisychain configurations or a combination of both.

Figure 1 shows an example of a radial cable layout. Note that all IB8 databus hubs connect directly back to the main Databus hub that is situated in the LH3 logger housing.

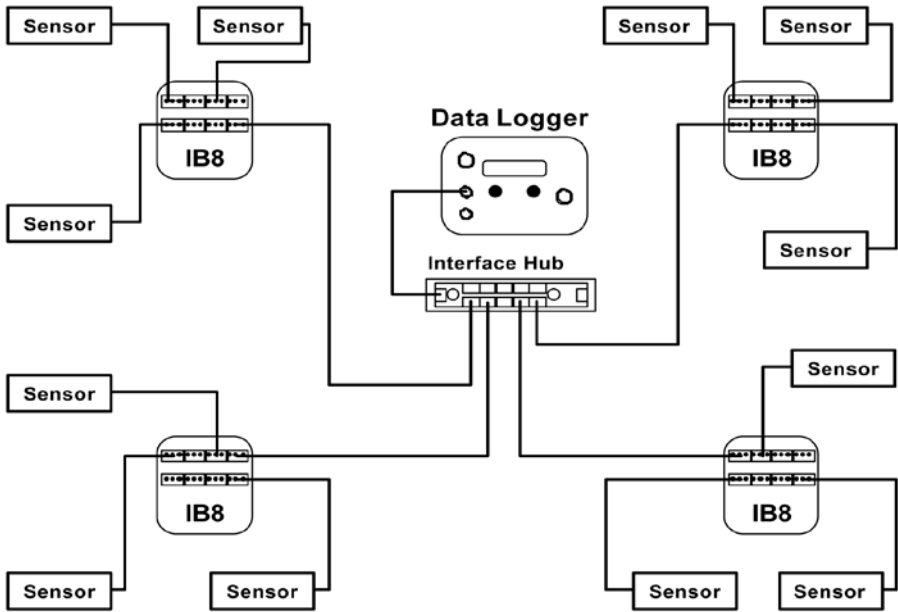

Figure 1

Figure 2 below shows an example of a daisychain cable layout. In this layout, the IB8 databus hubs are in series and there is only one connection back to the main databus hub.

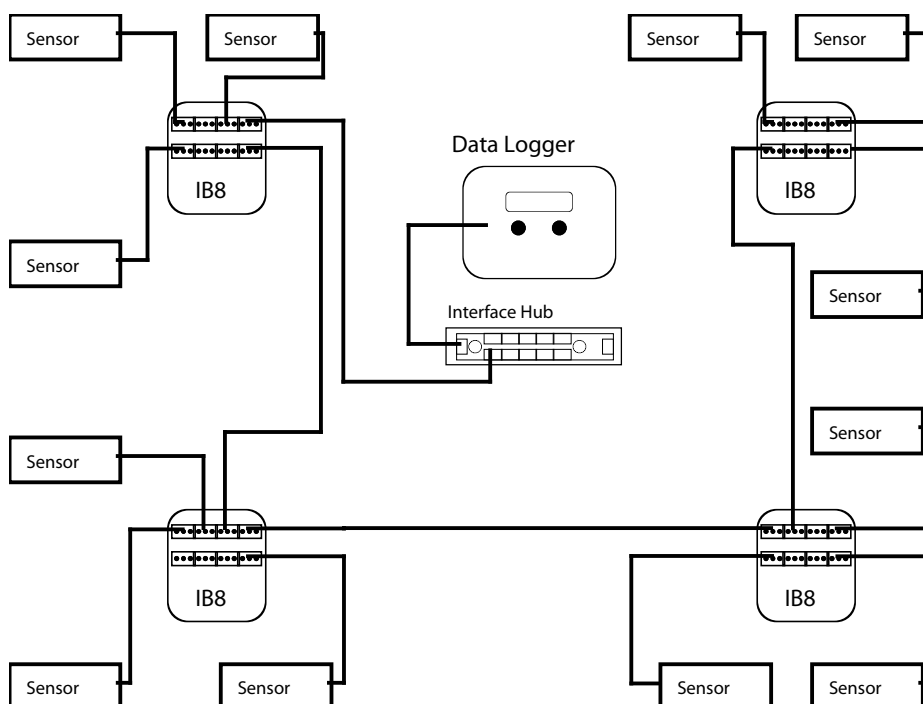

Figure 2

An important point to note with daisychaining is that the resistance effects of the extension cables will be cumulative. In the example of Figure 2 above, assuming the only power source is either the logger battery or an auxiliary battery connected to the Databus hub in the logger housing, then the sum of the resistance of all three Databus extension cables needs to be accounted for when determining a suitable wire gauge for the Databus cable. This is discussed further in the document titled Databus Extension Cables.

As stated earlier, customers can configure the cable layout as best suits the requirements of the system using a combination of both radial and daisychain options. If more connections are required, or a higher degree of weatherproofing, the IB8 hubs in the above examples can be substituted with the IB16 Databus hub.

An example of where a combination of both radial and daisychain layouts are utilised might be in a plant science experiment that is correlating the relationship between the transpiration rate of a large tree species and the available water in the soil. A radial layout might be utilised to fan out from the centrally located data logger to several tree groups. At the base of the trees, soil moisture sensors could be connected to the Databus hubs as shown in Figure 1. From these Databus hubs, extension cables might be daisychained up the trunk of the tree with Databus hubs providing connection points for Sapflow sensors at various heights as shown in Figure 2.