

SPECIFICATIONS

Measurement Range:

-10 to -1000 kPa

Resolution: 1 kPa

Measurement time:

30 seconds

Accuracy: +/- 5% of reading

Thermocouple type:

copper/constantan

Power requirements

Current Excitation: 50 mA

+/- 0.25 mA regulated

Current Drain: 75 mA for 31

second duration

Dimensions

Length of ceramic cylinder:

32 mm

Length of entire sensor:

60 mm

Diameter: 15 mm

Weight: 4 g for ceramic cylinder, 0.65 kg for entire sensor, cable and interface

Cable

Length: sensor has 3 m cable which is hardwired to the Smart Interface, the Interface is supplied with 5 m of cable

Related Products

SL5: Smart Logger

SEC 5000: Salinity Sensor

GT3-15: Tensiometer Transducer

FEATURES

- Data output in kPa
- Plug and Play
- Not subject to salts or dissolution

APPLICATIONS

- Desert soil hydrology
- Desert vegetation studies
- Store release covers
- Mining cover hydrology
- Landfill cover hydrology
- Soil mechanics

ORDERING INFORMATION

TM229-SMM Thermal matric Potential sensor and hardwired Smart Interface with 5 m of cable

Thermal Matric Potential Sensor

The thermal matric sensor TM229-SMM from ICT International is used to measure the soil matric potential in dry to very dry soils. Typical applications of this sensor are in the area of store release cover hydrology monitoring in mine and landfill closure and research on desert vegetation and hydrology.

The Thermal Matric Sensor (TM229-SMM) measures soil water potential from -10 to -1000 kPa. The instrument consists of a sensor with a heating element and a thermocouple encapsulated in epoxy in a hypodermic needle, which is encased in a porous ceramic matrix.

To calculate soil water matric potential, a 50 mA current is applied to the heating element of the sensor for a fixed time period of 24 seconds and the temperature rise is measured.

The magnitude of rise in the temperature varies according to the amount of water in the porous ceramic matrix, which changes as the surrounding soil wets and dries. The variations in the thermocouple output are measured by the Smart Interface which determines soil water matric potential by applying a second order polynomial equation to the temperature rise. The calculated answer is output directly as kilopascals (kPa). The individual calibration for each TM229 sensor is programmed into the microprocessor based Smart Interface which incorporates the custom current excitation module required to supply the necessary 50 mA to the sensor.

Smart Interface

The benefit of the Smart Interface is that as each TM229 is individually controlled there is no limitation on channels with the Smart Logger. No additional current excitation modules are required and no degradation of mechanical relays occurs, which makes other datalogger systems with multiplexer channels unsuitable for additional sensor applications.

The interface is environmentally sealed so it can be buried in the soil at the same depth as the sensor. This ensures there is no thermal gradient introduced between the sensor and interface by having them separated. A very important consideration due to the size of the temperature rise being measured in microvolts.

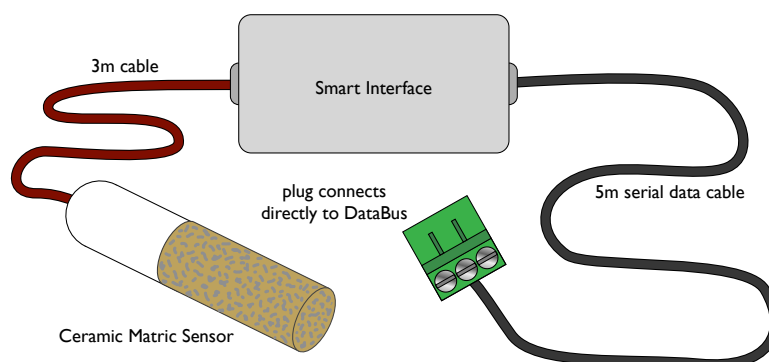

ICT International Pty Ltd
PO Box 503, Armidale NSW 2350, Australia
Ph: [61] 2-6772-6770 Fax: [61] 2-6772-7616
sales@ictinternational.com.au

